

CAD FILE:

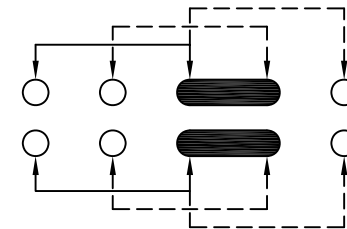

SCHEMATIC (SHORTING)

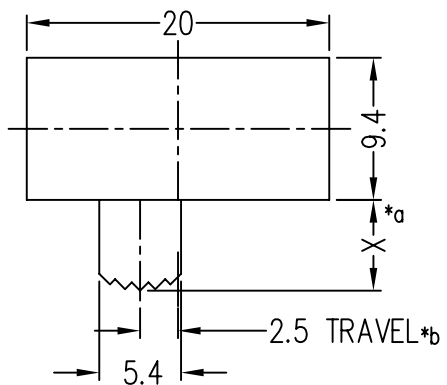
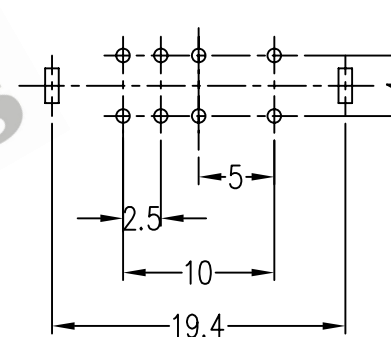
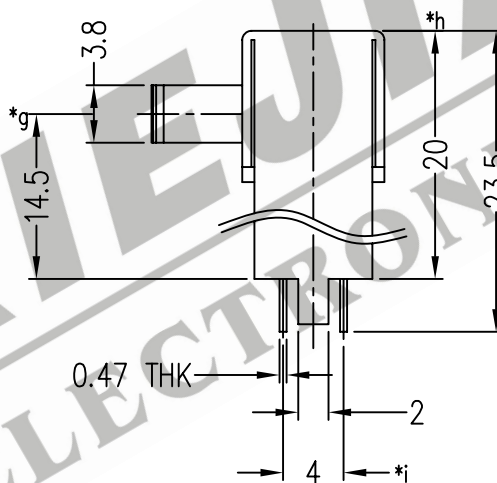
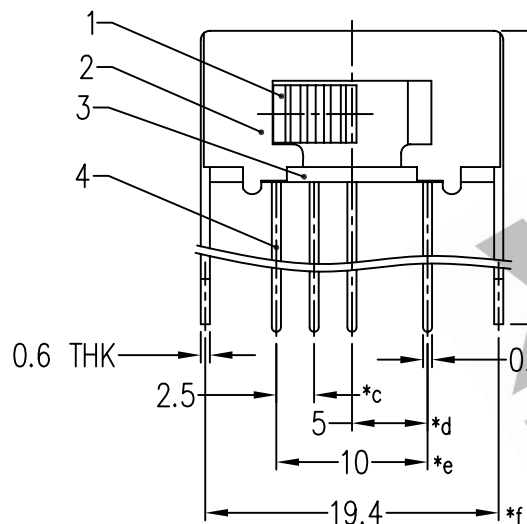

P.C.B LAYOUT

注:*表示关键尺寸(9个)

8					TOLERANCE UNLESS SPECIFIED	SHENZHEN XIEJIA ELECTRONICS CO.,LTD.				
7	STEEL STRIP	STEEL	1	NATURAL	WITHIN: 1.5 ±0.1mm	ISSUE	DATE	DESCRIPTIONS		APPD
6	SPRING	STAINLESS STEEL	1	TEMPER	OVER: 1.5 ±0.2mm					
5	CONTACT (CLIP)	PBS STRIP	2	Ag PLATED	TITLE: HORIZONTAL SLIDE SWITCH	UNIT : MM	DRWG NO.: XJ-DR-SK23E06-00			
4	TERMINAL	BRASS STRIP	8	Ag PLATED OVER Ni PLATED	MODEL: SK-23E06	SCALE: 2:1	DWN	ZHOUYU	2007-12-5	
3	TERMINAL BASE	PHENOLIC RESIN	1	NATURAL	ALL MATERIALS MUST BE COMPLIANT TO ROHS		CHK'D	FANGYING	2007-12-5	
2	FRAME	STEEL STRIP	1	Ni PLATED			APPD	KANGXINAN	2007-12-5	
1	KNOB	POM	1	BLACK						
NO.	PART NAME	MATERIAL	QTY	FINISHING						